

All New Electronics
COMPUTORQ II

ELECTRONIC TORQUE WRENCH



Precision Tools for the 21st Century

CDI TORQUE
PRODUCTS

COMPUTORQ II

CONGRATULATIONS ON THE PURCHASE OF THE MOST SOPHISTICATED, YET USER FRIENDLY ELECTRONIC TORQUE WRENCH MANUFACTURED TODAY. WITH MINIMUM MAINTENANCE, YOUR WRENCH SHOULD PROVIDE YEARS OF TROUBLE FREE SERVICE. PLEASE READ THE ENTIRE OPERATING MANUAL TO OBTAIN THE MAXIMUM PERFORMANCE FROM YOUR NEW WRENCH.

COVER	1
TABLE OF CONTENTS	2
FEATURES OF COMPUTORQ II	2
KEY PAD FUNCTIONS	3
OPERATING INSTRUCTIONS — SET UP	4 – 5
OPERATING INSTRUCTIONS — FUNCTIONS	6 – 7
DIAGRAM — USE OF ADAPTERS/COMPUTORQ II COMMUNICATION	8
DIAGRAM — SMALL AND LARGE ELECTRONIC WRENCH DESIGNS	9
SPECIFICATIONS OF ALL MODELS OF ELECTRONIC WRENCHES	9
CALIBRATION IN CLOCKWISE (CW) AND (CCW) DIRECTION	10 – 12
DIAGRAM — COMPUTORQ II ON A LOADER BEING CALIBRATED	13
DIAGRAM — ELECTRONIC WRENCH CONNECTED TO INTERFACE	13
DIAGRAM — BATTERY CONSERVATION SWITCH	13
INTERFACE CABLES FOR COMPUTORQ II	14
BATTERIES — REPLACEMENT, LOCATION AND USE	15
OTHER CDI MANUFACTURED PRODUCTS	16

FEATURES OF COMPUTORQ II

- ACCURACY TO +/- 1% INCREMENTS
- LARGE STORAGE OF TORQUE DATA MEMORY
- NEWEST ELECTRONICS AVAILABLE TODAY
- EXTREMELY ACCURATE AND REPEATABLE
- MICROPROCESSOR AND STRAIN GAUGE BASED TECHNOLOGY
- SELECTABLE MODES OF OPERATION
- DOWN-LOADING OF TORQUE DATA VIA RS 232 PORT
- EASY SET-UP OF TORQUE PARAMETERS
- LARGE RANGE OF TORQUE CAPACITIES 5 IN.LBS. TO 1,000 FT.LBS.
- USE OF STANDARD 9 VOLT ALKALINE BATTERIES
- AUDIO INDICATORS
- VISUAL INDICATORS
- TORQUE DIRECTIONAL INDICATOR
- ANALOG BAR GRAPH
- TARGET TORQUE VALUE SIGNALING WITH HI/LOW PERCENTAGE INDICATORS
- SEVEN (7) TORQUE ENGINEERING UNITS THAT ARE SELECTABLE
- OVER-LOAD INDICATOR
- SLEEP MODE FOR BATTERY CONSERVATION
- RECALL OF STORED MEMORY TORQUE VALUES ON LCD — UP TO 999
- DOWNLOADS TO A HOST OF PERIPHERALS
- AUDIO TONE FOR DATA ACCEPTANCE VIA KEYPAD
- LOW BATTERY INDICATOR
- BAUD RATES SELECTABLE FROM 300 bps TO 19,200 bps
- AUTOMATIC COMPENSATION FOR USE WITH ADAPTERS AND
- MUCH, MUCH MORE...

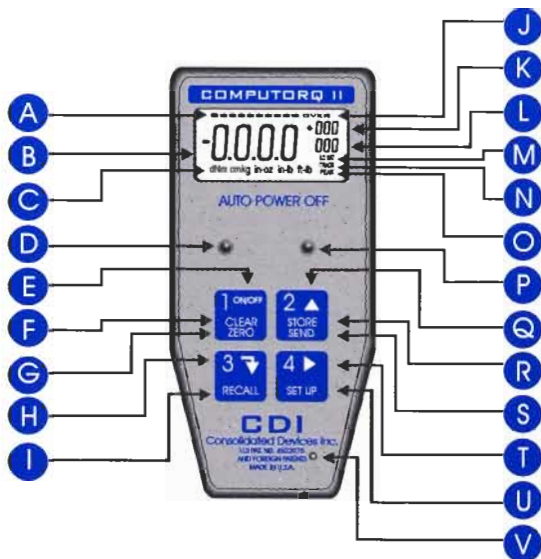

KEY PAD FUNCTIONS

- | | |
|---|--|
| A ANALOG BAR GRAPH | M LOW BATTERY INDICATION |
| B SUPER TWIST LIQUID CRYSTAL DISPLAY | N TRACK MODE |
| C 7 TORQUE UNITS (Ft.Lb., In.Lb., In.Oz., Nm, dNm, MKG, CmKG) | O PEAK HOLD MODE |
| D GREEN "GO" LIMIT LED | P RED "OVER TORQUE" LIMIT LED |
| E POWER ON/OFF | Q SCROLL UP (INCREASE VALUE DURING SET-UP) |
| F CLEAR LCD DISPLAY | R STORE DATA TO WRENCH |
| G ZERO TARE | S SEND DATA TO COMPUTER/DATA LOGGER/ PRINTER |
| H ENTER (ACCEPT INFORMATION) | T SHIFT TO NEXT FLASHING DIGIT (DURING SET-UP) |
| I RECALL TORQUE DATA STORED IN MEMORY | U SET-UP PARAMETERS (TOLERANCE LIMIT/TORQUE UNIT) |
| J OVER TORQUE "WARNING" | V AUDIO BUZZER |
| K SPECIFIC TORQUE NUMBER IN MEMORY BEING RECALLED AND SHOWN ON LCD | |
| L NUMBER OF TORQUE VALUES IN MEMORY | |

4 OPERATING INSTRUCTIONS FOR ALL ELECTRONIC MODELS

Please Note: There is an "off-on" slide switch located on the right side of the wrench. The wrench is shipped from the factory with the switch in the "off" position. Before use, slide the switch up or "on". Place the switch in the "off" position only if the wrench is to be stored or not used for a period of time. Otherwise, leave the switch in the "on" position.

ELECTRONIC WRENCH SETUP

• TO TURN WRENCH "ON"

Press Button #1 (on/off).

Slide battery selector switch "Up" (on) or press Button #1 (on/off) if slide switch is already in the "Up" position.

The red and green lights will flash.

Zeros will flash and then be displayed on the LCD along with the unit of torque measure.

The wrench is ready to use.

NOTE: If button #1 is pressed **and held** when first turning the wrench "on", the torque range capacity and current software version of program will be displayed. When first turning the wrench on (sliding the switch "up"), the LCD will flash "data good" then flash all zeros.

• TO CHANGE MODE OF OPERATION: "TRACK" OR "PEAK"

1. Press Button #4 (set-up) one time.

Either "Track" or "Peak" will be flashing.

2. To change the mode, press Button #2 (store/send). Continued pressing of Button #2 (store/send) will toggle between "Track" and "Peak"

3. Press Button #3 (recall) to accept the desired "flashing" mode change into wrench memory.

• TO CHANGE UNIT OF TORQUE MEASURE: In.Lb., In.Oz., NM, dNM, MKG, CmKG, Ft.Lb.

1. Press Button #4 (set-up) two times.

The unit of measure will flash on the display.

2. To change the unit of measure, press Button #2 (store/send). Continue pressing Button #2 (store/send) until the unit of measure desired is blinking on the LCD.

3. Press Button #3 (recall) to accept this change into the wrench memory.

• TO SET A TARGET TORQUE VALUE:

1. Press Button #4 (set-up) three times.

The first zero (0) on the digital display will blink.

2. To set a nominal target value into wrench memory, press Button #2 (store/send). As this button is repeatedly pressed, numbers zero through nine (0-9) will be displayed.

3. When the correct number is displayed on the first digit, press Button #4 (set-up). This will "hold" that number and cause the second digit to blink.

4. Again, press button #2 (store/send) until the value desired is displayed (0-9).

5. Press Button #4 (set-up) to "hold" this value and cause the third digit to blink.

6. Continue the same steps above to set the values for the third and fourth digits.

7. After pressing Button #4 (set-up) on the last digit, the decimal point will be blinking. This "point" can be placed in three different locations by pressing Button #2 (store/send). Press Button #4 (set-up) when the decimal point is in the desired location.



EXAMPLE



FLASHING



FLASHING



FLASHING

• TO SET PERCENTAGES OF TOLERANCES:

1. Press Button # 4 (set up), until the first digit of two in the upper right corner is blinking.
2. This will be the first of two digits in the (+) maximum tolerance percentage. Again, as before, press Button #2 (store/send) until the first digit is set at the desired value. Press Button #4 (set-up) to accept this value and move to the next blinking number.
3. Repeat the above procedure for the second digit. When the desired digit is displayed, press Button #4 (set-up). The maximum tolerance is now entered.
4. The first digit of the (-) minimum tolerance should be flashing. Press Button #2 (store/send) to scroll through numbers (0-9). Press Button #4 (set-up) to accept this value and move to the second flashing digit. Press Button #2 (store/send) to scroll through numbers (0-9) until the second desired number is displayed.



NOTE: Review the entire LCD at this time. If everything is as desired, press Button #3 (recall) to accept all parameters into wrench memory. These parameters will remain in memory until they are changed.



EXAMPLE SET-UP

To set a 250 in.lb. Computorq II to a nominal “target” value of 100 in.lbs. +/- 2% the following steps would be necessary:

1. Press Button #1 to turn the wrench “on” (check to see if “peak” is active)
2. Press Button #4 twice and verify if the active torque units are in in. lbs.
3. Press Button #4 one more time to activate the first blinking “0”.
4. Press Button #2 until the number “1” is displayed.
5. Press Button #4 five times to scroll through the three remaining zeros and the decimal point placement.
6. Press Button # 4 one more time to scroll through the first zero of the (+) maximum percentage. The second digit should be blinking.
7. Press Button #2 until the number “2” is displayed on the second digit.
8. Press Button #4 twice to the second digit of the (-) minimum percentage.
9. Press Button #2 until the number “2” is displayed on the second digit.
- * **Review Entire LCD at this time.**
10. Press Button #3 to place all above parameters into memory of wrench.

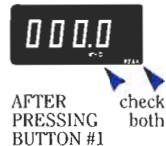

PLEASE NOTE: The wrench will sound an audible signal and a green light will flash when the applied torque to the wrench reaches the lower acceptable torque limit of 98 in.lbs. (100 in.lbs - 2%). The green light and audible tone will continue until the torque value reaches the maximum preset limit of 102 in.lbs. (100 in.lbs. + 2%). The red & green lights will flash and intermittent tones will sound if the torque value exceeds the maximum percentage allowed. Loud audible tones and flashing lights will continue even when an over torque (of the range of the wrench) condition occurs. The display will then show “OVER” in small letters in the extreme upper right of the display. After a over torque of 15% of the range of the wrench, “OvEr” will be displayed on the LCD. Damage may have already occurred.

GREEN LIGHT & TONE



RED LIGHT & TONE



ELECTRONIC WRENCH FUNCTIONS

• TO USE IN "TRACK" MODE OF OPERATION:

1. Turn wrench "on". Check to see if wrench is in "TRACK" mode
2. Place wrench on a fastener and apply a force. The value on the LCD will rise with the applied torque and then decrease when this force is removed. Thus, the values will "track-up" and then "track down"



• TO USE IN "PEAK" MODE OF OPERATION:

1. Turn wrench "on".
2. Refer to page 4 - "TO CHANGE MODE OF OPERATION" if wrench is not in "PEAK" mode.
3. Apply a force with the wrench, the highest torque value will be held on the LCD.



EXAMPLE

• TO USE MEMORY FEATURE IN PEAK MODE OF OPERATION:

1. Set up wrench to "Peak" mode of operation (see page 4).
2. Load the wrench to correct applied torque desired. Release the force applied. The maximum torque (peak) will remain on the display.

NOTE: YOU NOW HAVE TWO OPTIONS

- A. Press Button #2 (store/send) to store this torque value into memory. The display will clear to all zeros (000.0). The number "001" will appear in the lower right of the display. Repeat step 2 above and then press Button #2 (store/send) until the desired number of applied torque values is reached.
- B. Press Button #1 (clear/zero) and LCD will clear...wrench is ready for new torque operation. No value is stored in memory.



BEFORE



AFTER
PRESSING
BUTTON #2

• TO RECALL DATA STORED IN MEMORY TO THE LCD:

1. Press Button #3 (recall). The torque values placed in memory will appear on the digital display in the reverse order that they were placed in memory. Example: Last torque value taken and placed into memory is first to be recalled. The sequence number will be displayed in the upper right of the display (just above the total number of stored torque values in memory).
2. Continued pressing of Button #3 (recall) will scroll through all torque values in memory.



AFTER
PRESSING
BUTTON #3

• TO DOWNLOAD THE STORED DATA TO A PRINTER OR COMPUTER:

1. Press Button #3 (recall) at any time during the torque sequence (see above).
2. Then press Button #2 (store/send). The display will show the values are being sent by indicating "SEnd" on the LCD and will signal when all the data has finished being transmitted by a audible tone and the LCD display returning to the last torque value left on the display.
3. If, after a single torque value has been taken, and you wish to "send" this value to a peripheral, press and hold Button #2 (store/send) for approx. 2 seconds. A tone indicates completion of this function. If this torque value also needs to be placed into memory, press button #2 (store/send) once.

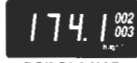

SCROLLING
THROUGH
MEMORY



BEFORE
SENDING



SENDING

PLEASE NOTE: When downloading recalled memory to a printer or computer, the data will be sent and printed in the order torque values were taken.

Example: First value taken will be first value printed.

* Please refer to page 14 for proper cabling and page 10 for factory set parameters.

** If "Err" is displayed on the LCD during transmission of torque data, the battery may need to be replaced. See page 15 for battery replacement diagrams.

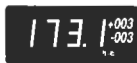

AFTER ALL
VALUES SENT

OPTIONS:

A. After data is sent, or TO CLEAR MEMORY ANYTIME, during this process press Button #1 (clear/zero) TWICE in rapid succession. An audible tone is sounded indicating all stored data in memory will be erased. The display will read "CLR" and then all zeros.

PLEASE NOTE: Data being sent to a printer or computer may be terminated at any time by pressing Button #2 (store / send).

B. To continue to add more values to the existing memory, press Button #4 (set-up) and take more torque readings.

PLEASE NOTE:

A. To prevent stored torque values in memory from being cleared erroneously, an operator must first have recalled torque values on the LCD by pressing Button #3 (recall) and then pressing Button #1 (clear/zero) twice.

B. While applying a load to the fastener, in "TRACK" mode, care must be used by the operator to assure that the applied torque is "held somewhat steady" while Button #2 (store/send) is pressed. Computorq II's microprocessor will capture and store the values on the display the instant Button #2 (store/send) is pressed.



BEFORE PRESSING BUTTON #1



AFTER PRESSING BUTTON #1 ONCE



AFTER PRESSING BUTTON #1 TWICE

• **TO TURN WRENCH "OFF":**

Press and hold Button #1 (clear / zero) for approximately 2 seconds. An audible tone will signal and the display will turn blank. If the wrench is to be stored or not used for prolonged periods of time, slide the "off-on" switch to the "off" position to conserve battery life.

• **BAR GRAPH FUNCTION**

A ten segment bar graph on the top of the LCD is a reference for the operator of the relative position of applied torque to the full range of the wrench. This is whether in track or peak modes.

EXAMPLE: 250 Ft.Lb. Wrench - Torquing in Clockwise Direction



If there is a TARGET torque value with percentage tolerances, the ten segment bar graph will show full scale AT THE TARGET VALUE - not the wrenches' full scale.

EXAMPLE: 250 Ft.Lb. Wrench set at 100 Ft.Lb.- Torquing in Counter-Clockwise Direction



PLEASE NOTE:

A. The next time the wrench is turned "ON", the same parameters as last used will still be active until changed.

B. If "Err" is displayed on the LCD (flashes at any time) the wrench should be turned off and then on with **NO LOAD** on the wrench. If "Err" continually appears on the LCD after performing the above procedure, return the wrench to the factory for evaluation.

IMPORTANT NOTICE: Please read the following cautions and warnings before using your electronic torque wrench.

COMPUTORQ II is, in effect, a transducer. Torque transducers are sensitive measuring instruments. "Over Torquing" past the useable torque range of the wrench may result in permanent damage. Always load the wrench slowly and do not exceed the useable range in any application.

THIS IS THE FORMAT USED FOR *COMPTON* II RS-232 COMMUNICATION

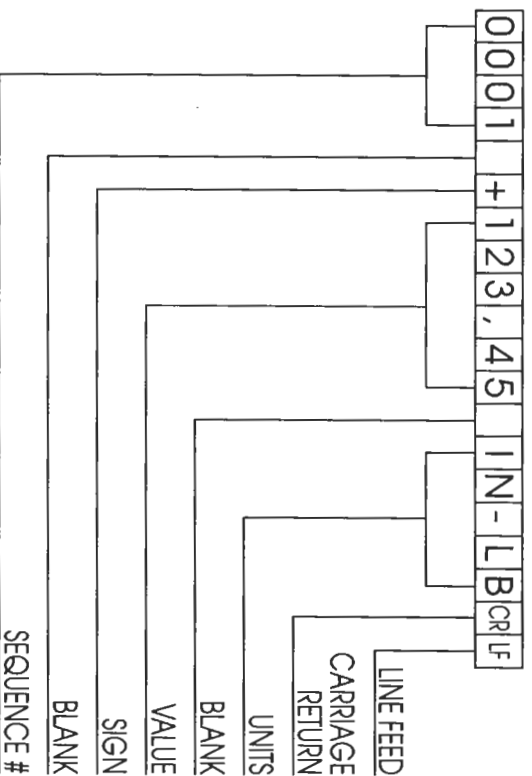

COMPTON II PROTOCOL:
1200, 8 BIT, NO PARITY, 1 STOP

PROCEDURE FOR USING ADAPTERS

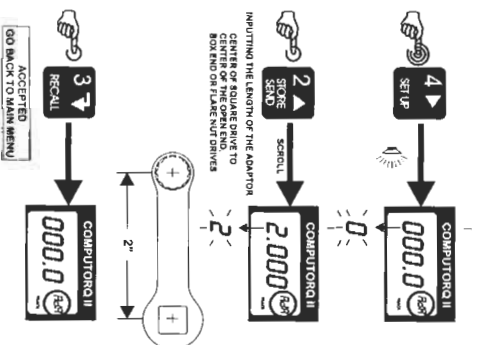

INSTRUCTIONS LEGEND

- LIGHT ON
- BUZZER SOUNDS
- PRESS
- PRESS + HOLD UNTIL BUZZER SOUNDS

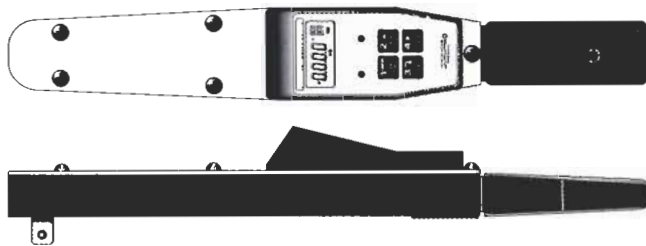

ELECTRONIC WRENCH
50 & 250 In.Lb. Models • 50 Ft.Lb. Model



ELECTRONIC WRENCH
250, 600 & 1000 Ft.Lb. Models

CALIBRATION PROCEDURES FOR COMPUTORQ II ELECTRONIC TORQUE WRENCHES

Due to the accuracy and the sensitivity of the Computorq II electronic torque wrench, a mechanical torque loader with a torque display (preferably electronic) must be used for input torque. The loader is necessary because the human hand cannot "push" or "pull" on the wrench with enough stability for the torque input to be an accurate value.

The calibration procedure must be done in both directions (CW and CCW).

Please consider the following calibration precautions:

- Make sure the Computorq II is level (or horizontal) while in the loader. If not, side loading may affect the true readings.
- Make sure the "reaction point" is in the center of the grip or handle.
- Make sure the least amount of sockets and adapters are used when mating to the calibration equipment.
- Check all sockets and adapters for "excessive play." This could result in false loads being applied and shown on the display.
- Make sure the wrench is in the proper torque engineering units prior to calibrating.
- Make sure the wrench mode of operation is in "TRACK." See page 4 for Set-Up.

* Accuracy

+/- 1% From 20-100% of scale.

+/- 1%, plus 5 increments, from 10-20% of scale.

SPECIFICATIONS

PART NUMBER	DR.	RANGE	INCRMT.	LGTH.	WT. LBS.
501 CI-II	1/4"	5-50 In.Lbs.	.01 In.Lbs.	13.5"	1.5
2502 CI-II	3/8"	25-250 In.Lbs.	.1 In.Lbs.	14.9"	2.0
502 CF-II	3/8"	5-50 Ft.Lbs.	.01 Ft.Lbs.	14.9"	2.0
2503 CF-II	1/2"	25-250 Ft.Lbs.	.1 Ft.Lbs.	21.5"	3.2
6004 CF-II	3/4"	60-600 Ft.Lbs.	.1 Ft.Lbs.	46.5"	9.9
10005 CF-II	1"	100-1000 Ft.Lbs.	1 Ft.Lbs.	74.0"	19.0

Wrenches may be set up in 7 different torque engineering units: Ft.Lb., In.Lb., In.Oz., NM, dNM, MKG or CmKG. See page 4 ("TO CHANGE UNIT OF TORQUE MEASURE")

Factory set parameters: Transmission data rate is 1200 baud; Communication protocol is RS 232 ASCII, 8 data bit, no parity. Other options are available, please consult factory for additional information.

Please Note: Computorq II has an exclusive feature – when using extensions or adapters, Computorq II's electronics can automatically compensate for these extra lengths. See page 8 for diagram.

FIRST: Exercise the wrench to full scale 3 times in the CW direction before calibration sequence begins.

HOLD KEY  FOR 3 SECONDS (BUZZER ON)  FIRST DIGIT WILL BLINK

ENTER " CALIBRATE CW " CODE 5251 BY :

- A/- PRESS KEY  SCROLL UP TO (5) PRESS KEY  SHIFT NEXT DIGIT
- B/- PRESS KEY  SCROLL UP TO (2) PRESS KEY  SHIFT NEXT DIGIT
- C/- PRESS KEY  SCROLL UP TO (5) PRESS KEY  SHIFT NEXT DIGIT
- D/- PRESS KEY  SCROLL UP TO (1) PRESS KEY  SHIFT NEXT DIGIT
- E/- PRESS KEY  ACCEPTED CODE 5251

BUZZER WILL TURN ON AND LCD WILL DISPLAY



FULLY LOAD WRENCH IN CW DIRECTION UNTIL "LOAD" ON LCD DISAPPEARS AND DISPLAY SHOWS ("0--0" / "--00-")

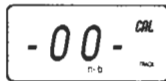

FULLY UNLOAD WRENCH AND WAIT 10 SECONDS , THEN PRESS KEY  LCD WILL DISPLAY "0" KEEP AN EYE ON THE ELECTRONIC DISPLAY LOAD TO FIRST VALUE

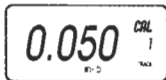

⊙ THE FIRST CALIBRATION POINT , SET BY MANUFACTURER

PRESS KEY  TO ACCEPT

SAMPLE

BUZZER WILL TURN OFF AND ON 10 TIMES LCD DISPLAY WILL COUNT DOWN FROM 10 TO 0 , AND DISPLAY "0"

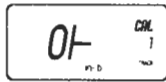

⊙ NOTE : DURING PROCESS , HOLD THE WRENCH VERY STILL UNTIL " 0 " IS DISPLAYED

LCD WILL DISPLAY "0" KEEP AN EYE ON THE ELECTRONIC DISPLAY LOAD TO SECOND VALUE

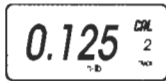

⊙ THE SECOND CALIBRATION POINT , SET BY MANUFACTURER

PRESS KEY  TO ACCEPT

SAMPLE

BUZZER WILL TURN OFF AND ON 10 TIMES LCD DISPLAY WILL COUNT DOWN FROM 10 TO 0 , AND DISPLAY "0"

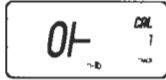

⊙ NOTE : DURING PROCESS , HOLD THE WRENCH VERY STILL UNTIL " 0 " IS DISPLAYED

YOU ARE DONE





NOTE: Follow the above directions as closely as possible. Please be careful to "LOAD" the wrench ONLY during the indicated times - overtorquing past the range of the wrench is very possible and could cause damage without audio/visual indicators being active during calibration.

NOTE: When "OK" is displayed after the second calibration check point has been checked/adjusted, the LCD should then show the torque presently being applied.

FIRST: Exercise the wrench to full scale 3 times in the CCW direction before calibration sequence begins.

HOLD KEY  FOR 3 SECONDS (BUZZER ON)  FIRST DIGIT WILL BLINK

ENTER " CALIBRATE CCW " CODE 5252 BY :

- A/- PRESS KEY  SCROLL UP TO (5) PRESS KEY  SHIFT NEXT DIGIT
- B/- PRESS KEY  SCROLL UP TO (2) PRESS KEY  SHIFT NEXT DIGIT
- C/- PRESS KEY  SCROLL UP TO (5) PRESS KEY  SHIFT NEXT DIGIT
- D/- PRESS KEY  SCROLL UP TO (2) PRESS KEY  SHIFT NEXT DIGIT
- E/- PRESS KEY  ACCEPTED CODE 5252

BUZZER WILL TURN ON AND LCD WILL DISPLAY



FULLY LOAD WRENCH IN CCW DIRECTION UNTIL "LOAD" ON LCD DISAPPEARS AND DISPLAY SHOWS ("0-0" / "-00-")



FULLY UNLOAD WRENCH AND WAIT 10 SECONDS, THEN PRESS KEY  LCD WILL DISPLAY "0" KEEP AN EYE ON THE ELECTRONIC DISPLAY LOAD TO FIRST VALUE

PRESS KEY  TO ACCEPT

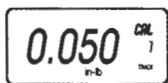

① THE FIRST CALIBRATION POINT, SET BY MANUFACTURER

SAMPLE

BUZZER WILL TURN OFF AND ON 10 TIMES LCD DISPLAY WILL COUNT DOWN FROM 10 TO 0, AND DISPLAY "0"

② NOTE : DURING PROCESS , HOLD THE WRENCH VERY STILL UNTIL "0" IS DISPLAYED

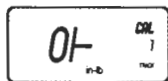

LCD WILL DISPLAY "0" KEEP AN EYE ON THE ELECTRONIC DISPLAY LOAD TO SECOND VALUE

PRESS KEY  TO ACCEPT

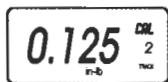

③ THE SECOND CALIBRATION POINT, SET BY MANUFACTURER

SAMPLE

BUZZER WILL TURN OFF AND ON 10 TIMES LCD DISPLAY WILL COUNT DOWN FROM 10 TO 0, AND DISPLAY "0"

④ NOTE : DURING PROCESS , HOLD THE WRENCH VERY STILL UNTIL "0" IS DISPLAYED

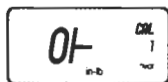

YOU ARE DONE

NOTE: Follow the above directions as closely as possible. Please be careful to "LOAD" the wrench ONLY during the indicated times - overtorquing past the range of the wrench is very possible and could cause damage without audio/visual indicators being active during calibration.

NOTE: When "OK" is displayed after the second calibration check point has been checked/adjusted, the LCD should then show the torque presently being applied.

COMPUTORQ II SHOWN
BEING CALIBRATED ON
A MECHANICAL
LOADER

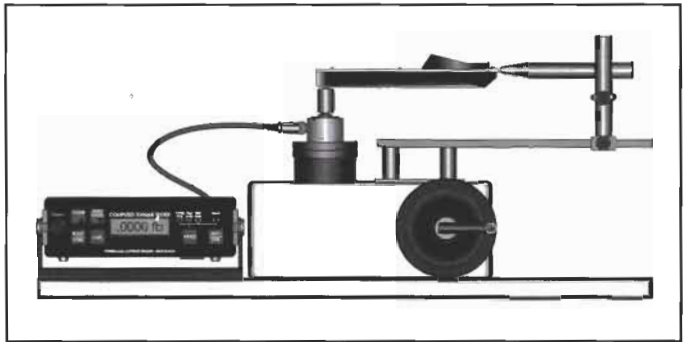

COMPUTORQ II SHOWN
CONNECTED TO DATA
LOGGER INTERFACE

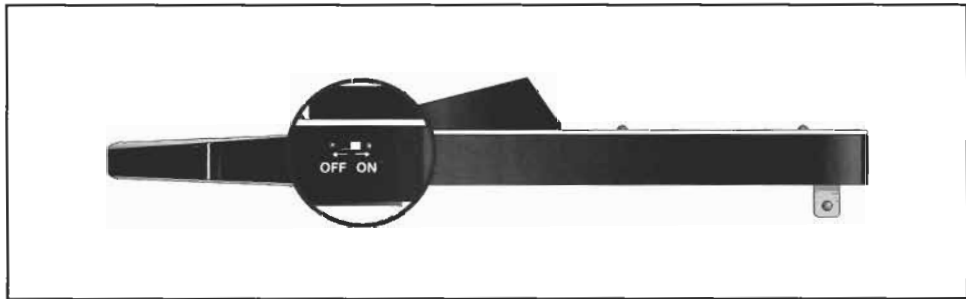

COMPUTORQ II FEATURES A BATTERY CONSERVATION SWITCH TO EXTEND THE BATTERY LIFE WHEN THE WRENCH IS NOT IN USE

INTERFACE CABLES FOR COMPUTORQ II

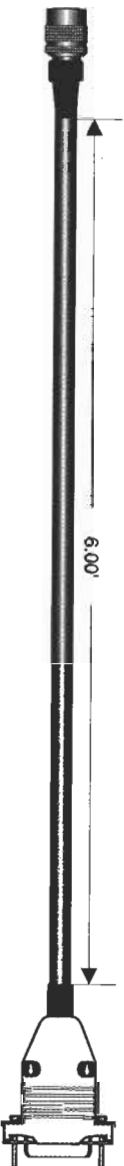

6 PIN MALE PLUG CONNECTOR

COMPUTORQ II TO PC

9 PIN FEMALE CONNECTOR

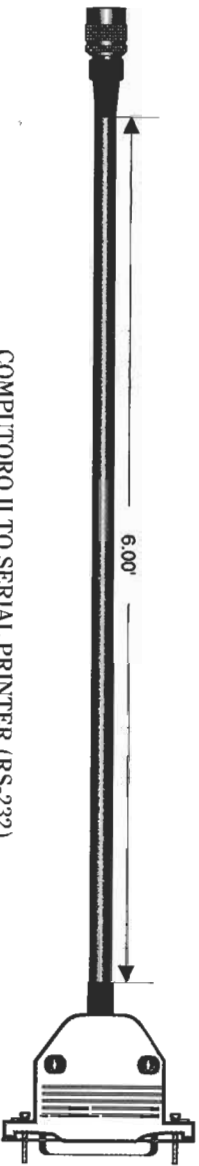

6 PIN MALE PLUG CONNECTOR

COMPUTORQ II TO SERIAL PRINTER (RS-232)

25 PIN FEMALE CONNECTOR

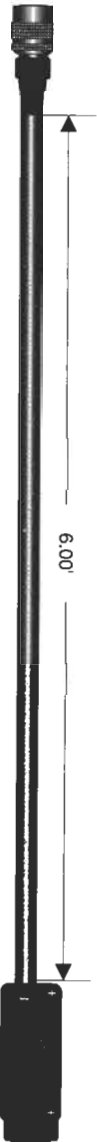

6 PIN MALE PLUG CONNECTOR

COMPUTORQ II TO MITUTOYO PRINTER

10 PIN FEMALE CONNECTOR

A 9-VOLT ALKALINE BATTERY IS STANDARD AND PROVIDES FOR APPROX. 60 HOURS OF OPERATION. A "LO-BAT" INDICATION ON THE DISPLAY SIGNALS FOR REPLACEMENT. THERE ARE 10 - 20 HOURS OF WRENCH OPERATION REMAINING, EVEN AFTER "LO-BAT" IS DISPLAYED. BATTERIES CAN BE CHANGED IN LESS THAN ONE MINUTE. PLEASE NOTE:

1. HAVE NEW AND FRESH BATTERIES READY TO INSTALL PRIOR TO BATTERY REPLACEMENT.
2. A FLASHING "LO-BAT" INDICATES BATTERY FAILURE IS IMMINENT. THERE ARE APPROX. 2-3 HOURS OF BATTERY LIFE REMAINING

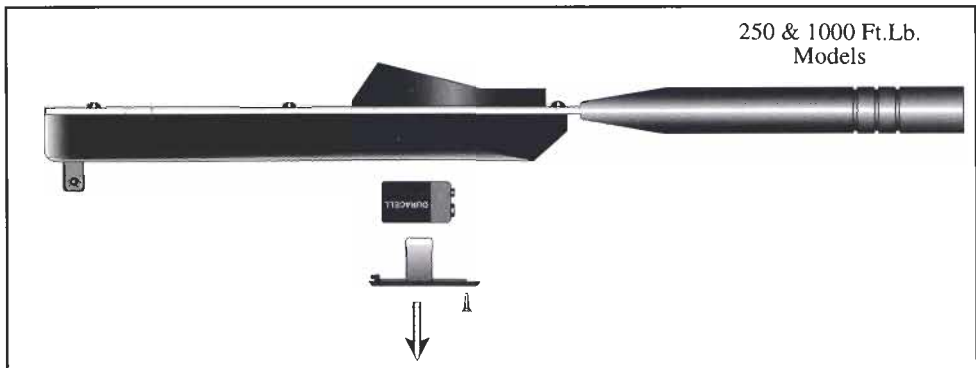
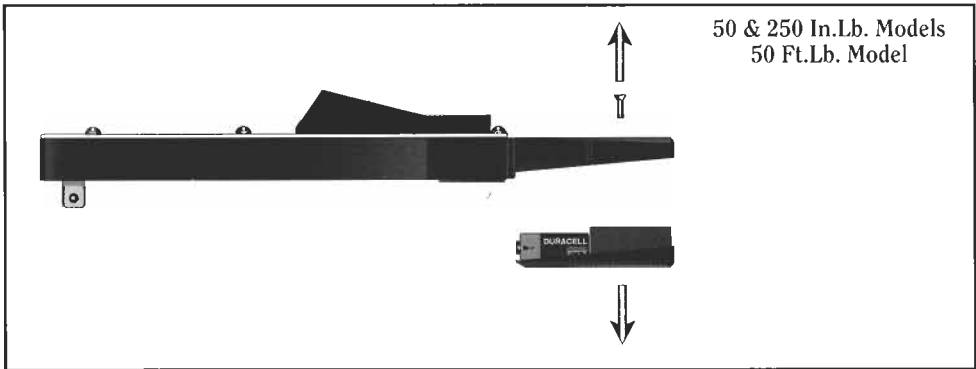
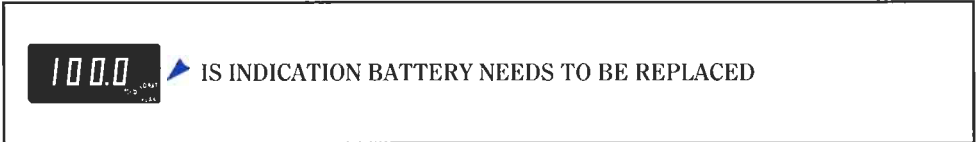

- Electronic Torque Testers
- Transducers
- Programmable Electronic Torque Wrench (PET)
- Electronic Torque Loaders
- Calibration Equipment
- Torque Multipliers
- Dial Wrenches
- Micrometer Wrenches
- Pre-Set Wrenches
- Screwdrivers
- Torkys
- Beam Torque Wrenches
- Mechanical Torque Testers and Loaders

Partial List of Our Customers

BOEING
 GENERAL MOTORS
 FORD
 CHRYSLER
 McDONNELL-DOUGLAS
 NASA
 CATERPILLER
 JOHN DEERE
 KENWORTH
 U.S. AIR FORCE
 U.S. NAVY
 U.S. ARMY
 SIKORSKY

CONSOLIDATED DEVICES, INC., (CDI) offers the industry's most comprehensive line of mechanical and electronic torque wrenches, torque testers, torque multipliers, transducers and related options and accessories.

For over 30 years, CDI has supplied its quality torque products to the Automotive, Nuclear and industrial markets throughout the world.

CDI engineers, manufactures and markets all products from our facility located in Southern California.

Our emphasis on applying electronic technology to torque products has resulted in the most sophisticated, yet user friendly, line of torque wrenches and testers manufactured in the world.

WARRANTY

Electronic torque wrenches are warranted against defects and workmanship for a period of one year from the date of purchase. CDI or any of their authorized representatives will, at their option, repair or replace any defective wrench if returned, postage prepaid, to an authorized repair station.

The forgoing obligation is CDI's sole liability and the purchaser's sole remedy under this warranty. There are no other warranties express or implied, including those of market ability or fitness for purpose. Under no circumstances shall CDI be liable for any special, incidental or consequential damage.

This warranty does not apply if the electronic torque wrench has been altered, damaged, abused or improperly maintained. This warranty gives you specific legal rights and you may have other rights which vary from state to state.

CDI **TORQUE**
 PRODUCTS

19220 San Jose Avenue • City of Industry, California 91748

800-525-6319 Fax 626-965-2410

www.cditorque.com

#OM-C-CDI
 4/01 REV. B